

### MU Series Plate Cylinder



#### Ordering Code MU Series Plate Cylinder

**M**  **U** **B**     **25** × **5**     -     **D**     **M Z**

**Magnet**     **Mounting**     **Bore**     **Stroke**     **Acting**     **Thread Type**

Blank: Without Magnet  
D: With Magnet

B: Basic  
L: Foot  
F: Rod Flange  
G: Head Flange  
C: Single Clevis  
D: Double Clevis  
\* Brackets are shipped together (but not assembled).

25: Equiv. Ø25 piston area  
32: Equiv. Ø32 piston area  
40: Equiv. Ø40 piston area  
50: Equiv. Ø50 piston area  
63: Equiv. Ø63 piston area

D: Double acting  
S: Single acting spring return  
T: Single acting spring extend  
W: Double shaft double acting

Nil: Rod end female thread  
M: Rod end male thread

\* Double force and multi-force cylinders are customized.

\* If a built-in magnet cylinder without an auto switch is required, there is no need to enter the symbol for the auto switch. (Example) MDUL32-30DZ

#### Specifications

Bore(mm)	25	32	40	50	63
Working medium	Air				
Acting type	Double acting, Single rod				
Guaranteed pressure	1.05MPa				
Max. Working pressure	0.7MPa				
Mini. Working pressure	0.05MPa				
Working temperature	-10 to 60°C				
Lubrication	Not required (Non-lube)				
Piston speed	50 to 500 mm/s				
Tolerance of stroke	+1.4 0				
Cushion Type	Rubber bumper				
Mounting	Foot, Rod flange, Head flange, Single clevis, Double clevis				
Rod end configuration	Rod end male thread, Rod end female thread				
Allowable rotational torque	0.25 N·m		0.55 N·m	1.25 N·m	2.0 N·m
Rod non-rotating accuracy	±1°	±0.8°		±0.5°	

### Main Dimensions MUB (Single Rod Double Acting Type)

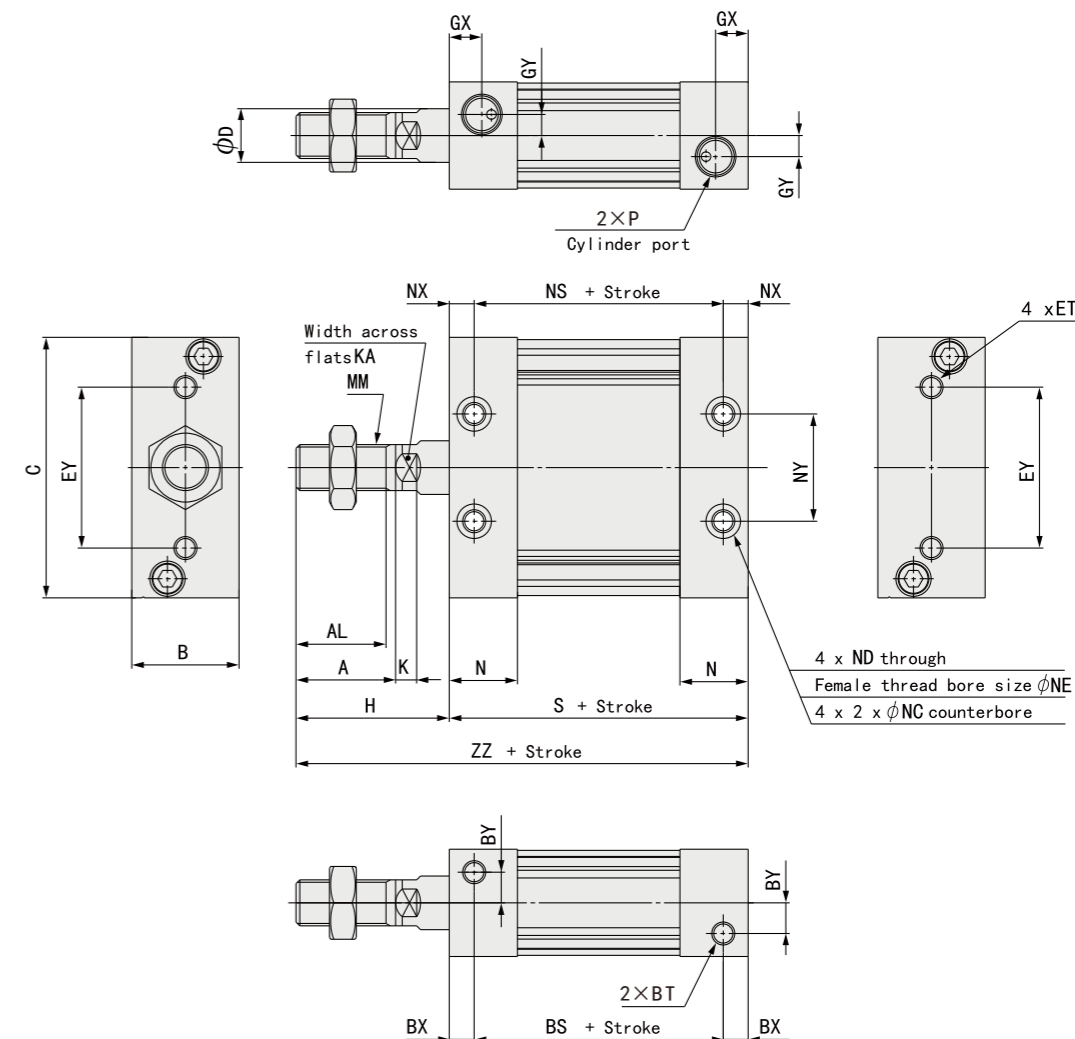

#### Rod End Male Thread

Model	Stroke range	A	AL	B	BS	BT	BX	BY	C	D	ET	EY	GX	GY	H	K	KA
MUB25	5 to 300	22	19.5	24	37	M5×0.8 depth 7.5	9	7	54	12	M5×0.8 depth 11	26	10	5	36	5.5	10
MUB32	5 to 300	26	23.5	28	45	M6×1 depth 12	6.5	8	68	14	M6×1 depth 11	42	8.5	5.5	40	5.5	12
MUB40	5 to 300	30	27	32	44	M8×1.25 depth 13	8	9	86	16	M8×1.25 depth 11	54	9	7	45	6	14
MUB50	5 to 300	35	32	39	54	M10×1.5 depth 14.5	10	9	104	20	M10×1.5 depth 15	64	11.5	8	53	7	18
MUB63	5 to 300	35	32	50	53	M12×1.75 depth 18	11	12	124	20	M12×1.75 depth 15	72	11.5	10	56	7	18

Model	MM	N	NC	ND	NE	NS	NX	NY	P			S	ZZ
									-	TN	TF		
MUB25	M10×1.25	16.5	7.5 depth 4.5	M5×0.8	4.3	43	6	26	M5×0.8	-	-	55	91
MUB32	M12×1.25	18	9 depth 5.5	M6×1	5.1	45	6.5	28	Rc1/8	NPT1/8	G1/8	58	98
MUB40	M14×1.5	18.5	10.5 depth 6.5	M8×1.25	6.9	44	8	36	Rc1/8	NPT1/8	G1/8	60	105
MUB50	M18×1.5	24	13.5 depth 8.5	M10×1.5	8.7	54	10	42	Rc1/4	NPT1/4	G1/4	74	127
MUB63	M18×1.5	24	17 depth 10.5	M12×1.75	10.5	53	11	46	Rc1/4	NPT1/4	G1/4	75	131

\* The position of the 4 flats of the piston rod is ±3° in relation to the cylinder side surface.

### MU Series Plate Cylinder

#### Main Dimensions MUB (Single Rod Double Acting Type)

##### Rod End Female Thread

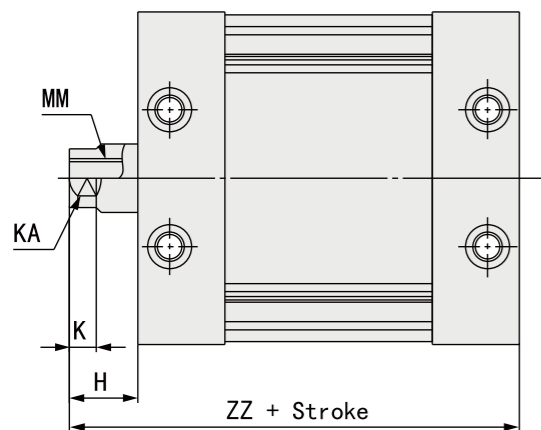

Model	H	MM	ZZ
MUB25	14	M6×1 depth 12	69
MUB32	14	M8×1.25 depth 13	72
MUB40	15	M8×1.25 depth 13	75
MUB50	18	M10×1.5 depth 15	92
MUB63	21	M10×1.5 depth 15	96

\* Dimensions except mentioned on the right are the same as male thread type.  
\* However, K and KA dimensions are the same as male thread type.

##### Rod End Nut

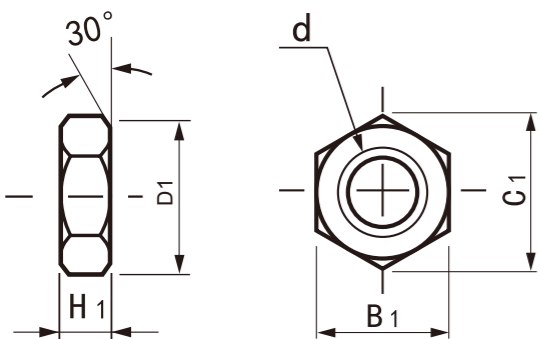

Part no.	Size	D	H1	B1	C1	D1
NT-03	25	M10×1.25	6	17	19.6	16.5
NT-MU03	32	M12×1.25	7	19	21.9	18
NT-04	40	M14×1.5	8	22	25.4	21
NT-05	50,63	M18×1.5	11	27	31.2	26

\* A nut is attached to the rod end male thread as standard.  
\* Rod end nut material: Carbon steel  
\* Surface treatment: Chromated

#### Theoretical Output

Size	Rod size (mm)	Operating direction	Piston area (mm <sup>2</sup> )	Operating pressure (MPa)					
				0.2	0.3	0.4	0.5	0.6	0.7
25	12	OUT	491	98	147	196	246	295	344
		IN	378	76	113	151	189	227	265
32	14	OUT	804	161	241	322	402	482	563
		IN	650	130	195	260	325	390	455
40	16	OUT	1257	251	377	503	629	754	880
		IN	1056	211	317	422	528	634	739
50	20	OUT	1963	393	589	785	982	1178	1374
		IN	1649	330	495	660	824	989	1154
63	20	OUT	3117	623	935	1247	1559	1870	2182
		IN	2803	561	841	1121	1402	1682	1962

\* Note) Theoretical output (N) = Pressure (MPa) × Piston area (mm<sup>2</sup>)

#### Main Dimensions MUW (Double Shaft Double Acting Type)

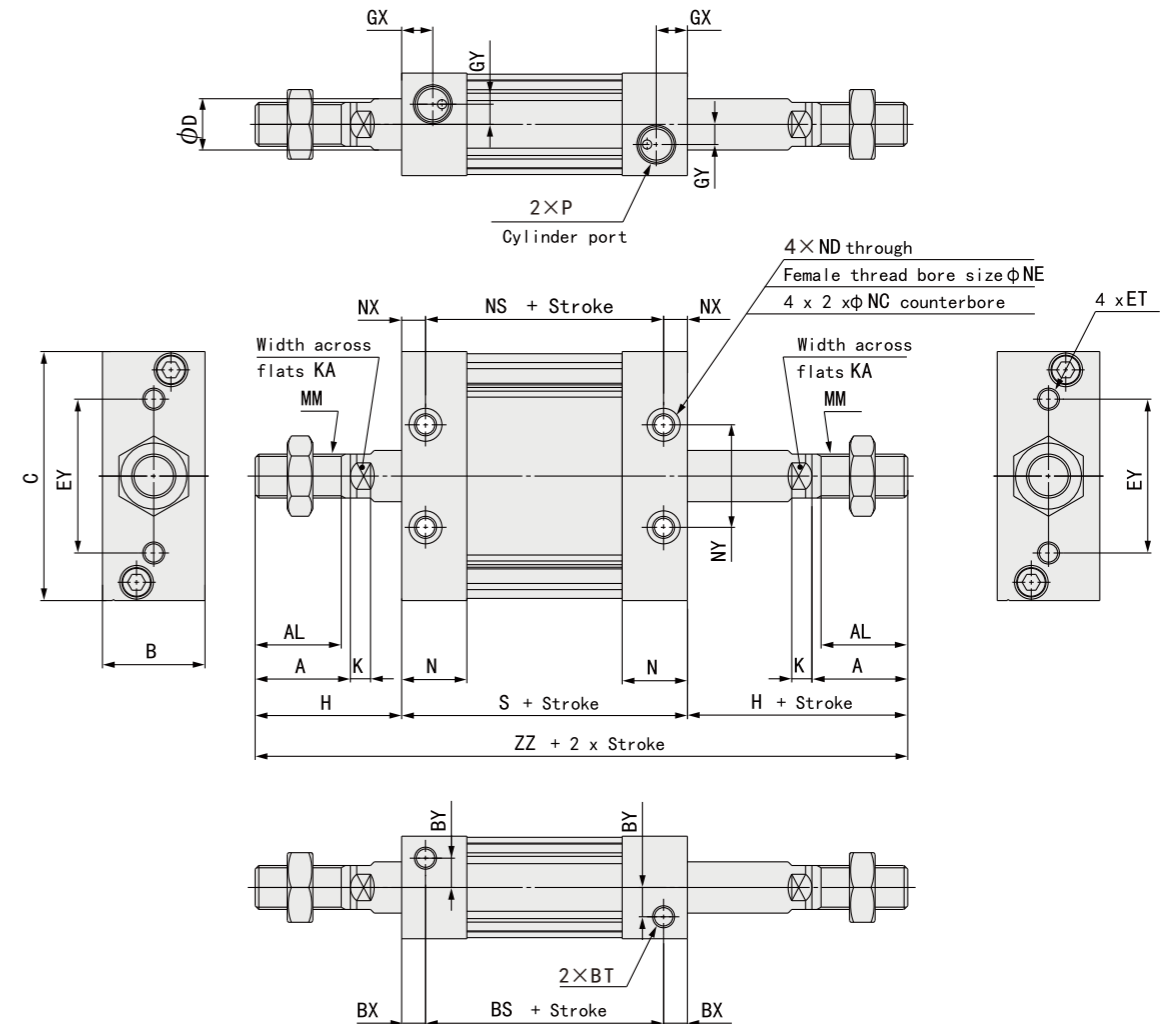

##### Rod End Male Thread

Model	Stroke range	A	AL	B	BS	BT	BX	BY	C	D	ET	EY	GX	GY	H	K	KA
MUW25	5 to 300	22	19.5	24	37	M5×0.8 depth 7.5	9	7	54	12	M5×0.8 depth 11	26	10	5	36	5.5	10
MUW32	5 to 300	26	23.5	28	45	M6×1 depth 12	6.5	8	68	14	M6×1 depth 11	42	8.5	5.5	40	5.5	12
MUW40	5 to 300	30	27	32	44	M8×1.25 depth 13	8	9	86	16	M8×1.25 depth 11	54	9	7	45	6	14
MUW50	5 to 300	35	32	39	54	M10×1.5 depth 14.5	10	9	104	20	M10×1.5 depth 15	64	11.5	8	53	7	18
MUW63	5 to 300	35	32	50	53	M12×1.75 depth 18	11	12	124	20	M12×1.75 depth 15	72	11.5	10	56	7	18

Model	MM	N	NC	ND	NE	NS	NX	NY	P			S	ZZ
									-	TN	TF		
MUW25	M10×1.25	16.5	7.5 depth 4.5	M5×0.8	4.3	43	6	26	M5×0.8	-	-	55	127
MUW32	M12×1.25	18	9 depth 5.5	M6×1	5.1	45	6.5	28	Rc1/8	NPT1/8	G1/8	58	138
MUW40	M14×1.5	18.5	10.5 depth 6.5	M8×1.25	6.9	44	8	36	Rc1/8	NPT1/8	G1/8	60	150
MUW50	M18×1.5	24	13.5 depth 8.5	M10×1.5	8.7	54	10	42	Rc1/4	NPT1/4	G1/4	74	180
MUW63	M18×1.5	24	17 depth 10.5	M12×1.75	10.5	53	11	46	Rc1/4	NPT1/4	G1/4	75	187

\* The position of the 4 flats of the piston rod is different from the above drawing. Position of the 4 flats of the piston rod for double rod type is not the same.

# MU Series Plate Cylinder

## Main Dimensions MUW ( Double Shaft Double Acting Type )

### Rod End Female Thread

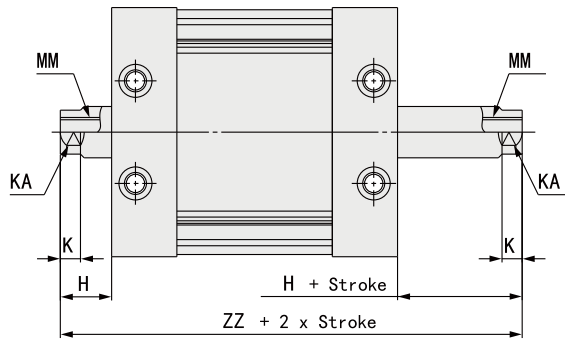

Model	H	MM	ZZ
MUW25	14	M6×1 depth 12	83
MUW32	14	M8×1.25 depth 13	86
MUW40	15	M8×1.25 depth 13	90
MUW50	18	M10×1.5 depth 15	110
MUW63	21	M10×1.5 depth 15	117

\* Dimensions except mentioned on the right are the same as male thread type.

\* However, K and KA dimensions are the same as male thread type.

### Rod End Nut

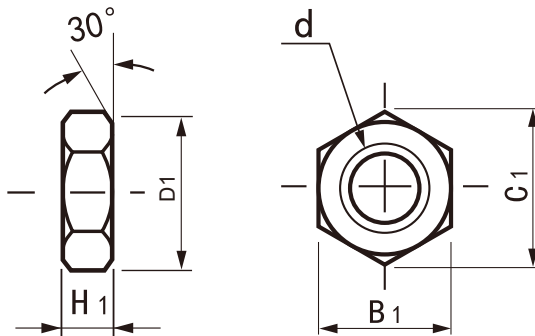

Part no.	Size	D	H1	B1	C1	D1
NT-03	25	M10×1.25	6	17	19.6	16.5
NT-MU03	32	M12×1.25	7	19	21.9	18
NT-04	40	M14×1.5	8	22	25.4	21
NT-05	50,63	M18×1.5	11	27	31.2	26

\* A nut is attached to the rod end male thread as standard.  
(2 pieces for double rod type)

\* Rod end nut material: Carbon steel

\* Surface treatment: Chromated

## Theoretical Output

Size	Rod size (mm)	Operating direction	Piston area (mm <sup>2</sup> )	Operating pressure(MPa)					
				0.2	0.3	0.4	0.5	0.6	0.7
25	12	IN/OUT	378	76	113	151	189	227	265
32	14	IN/OUT	650	130	195	260	325	390	455
40	16	IN/OUT	1056	211	317	422	528	634	739
50	20	IN/OUT	1649	330	495	660	824	989	1154
63	20	IN/OUT	2803	561	841	1121	1402	1682	1962

\* Note) Theoretical output (N) = Pressure (MPa) × Piston area (mm<sup>2</sup>)